

Morsetto clamp

Norme: DIN 32676 – ISO 2852 – BS 4825

Materiale: Aisi 304L – EN 1.4307

cod. 601K

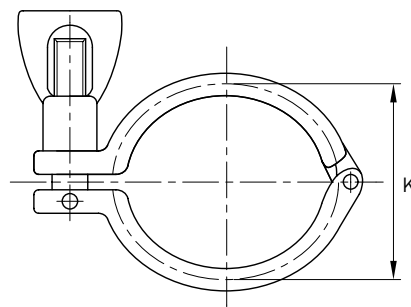

Morsetti per tronchetti clamp DIN 32676 (cod. 600D)

DN	K mm	Tubo DIN mm	Stock
15	34	18 x 1,5	R
20	34	22 x 1,5	R
25	50,5	28 x 1,5	R
32	50,5	34 x 1,5	R
40	50,5	40 x 1,5	R
50	64	52 x 1,5	R
65	91	70 x 2	R
80	106	85 x 2	R
100	119	101,6 x 2	R
125	155	129 x 2	R
150	183	154 x 2	R

Morsetti per tronchetti clamp ISO 2852 (cod. 600I)

DN	K mm	Tubo ISO mm	Stock
15	34	21,3 x 1,6	D
20	50,5	26,9 x 1,6	D
25	50,5	33,7 x 2	D
32	50,5	42,4 x 2	D
40	64	48,3 x 2	D
50	77,5	60,3 x 2	D
65	91	76,1 x 2	D
80	106	88,9 x 2	D
100	130	114,3 x 2	R
125	155	139,7 x 2	R
150	183	168,3 x 2,6	R

Morsetti per tronchetti clamp BS 4825 (cod. 600B)

DN inch	K mm	Tubo SMS mm	Stock
3/4"	25,2	19,05 x 1,65	R
1"	50,5	25,4 x 1,65	R
1 1/2"	50,5	38,1 x 1,65	R
2"	64	50,8 x 1,65	R
2 1/2"	77,5	63,5 x 1,65	R
3"	91	76,2 x 1,65	R
4"	119	101,6 x 2,10	R
6"	166,87	152,5 x 2,60	R
8"	217,67	203,3 x 2,60	R